

Double Speed Chain Conveyor

- This Conveyor is used double speed chain No.50.
- There are two types of rollers on the conveying surface, plastics or steel.
- When it uses plastic roller, the maximum conveyance weight of each 1m is 160kg. When it uses steel roller, the maximum conveyance weight of each 1m is 320kg. This conveyor can transport up to 690Kg. (depends on conveyance speed).
- Conveyor frame is NKE's original. Provide a dedicated nut (M8, M6) that can be back-in with low-back dimensions.
- Equipped with a resin guide suitable for Pallet conveyance as standard.
- It has Safety cover and Cross roller basically.

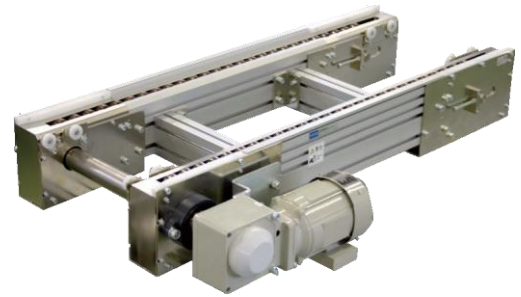

CSW103

Ordering Code

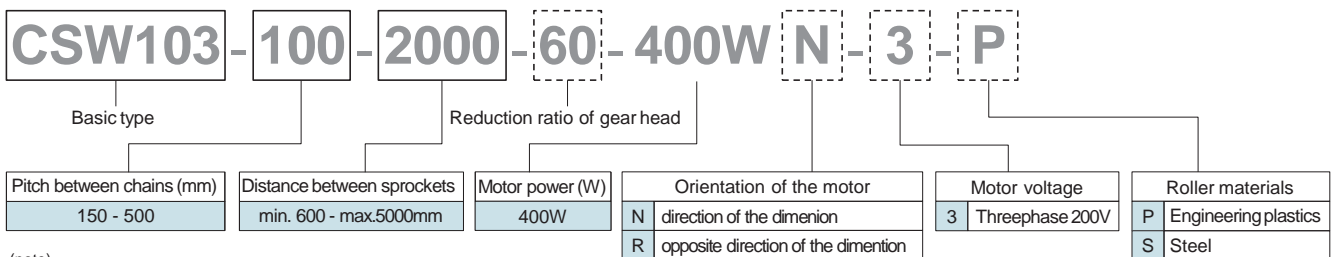

(note)
Contact us about another specifications
This is the geared motors. When you change the conveyance speed, you have to change all included motor.
Contact us when distance between sprockets L is over 5000mm

Reduction ratio of gear head and Conveyance speed

Reduction ratio of gear head	30	40	50	60	80	100	120	150	200
Conveyance speed (m/sec)									
50Hz	0.678	0.508	0.407	0.339	0.254	0.203	0.169	0.136	0.102
60Hz	0.818	0.613	0.491	0.409	0.307	0.245	0.204	0.164	0.123

The above conveyance speed shows without the load.
Therefore, it shall be calculated to reduce 2-15% from the chart according to the load.

Specification

Weight (kg)

Distance between sprockets (mm)	Surface material (Roller)	
	Engineering plastics	Steel
600 - 1000	58	60
1000 - 1500	69	72
1501 - 2000	79	84
2001 - 2500	90	95
2501 - 3000	100	106
3001 - 3500	112	118
3501 - 4000	122	130
4001 - 4500	132	140
4501 - 5000	143	153

The above shows the maximum weight of distance between sprockets.

Specification of Chain

Surface material (Roller)	Engineering plastics	Steel
Pitch	31.75mm	31.75mm
Inner large dia. roller width	13.0mm	13.0mm
Inner large dia. roller dia.	30.6mm	30.6mm
Inner small dia. roller width	7.1mm	7.1mm
Inner small dia. roller dia.	19.05mm	19.05mm
Heat resistance	-10 °C to 60 °C	-10 °C to 150 °C

* Please use lubricant for high temperatures when using it over 60 degree.

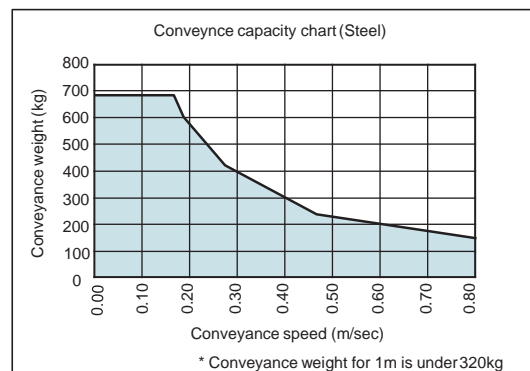
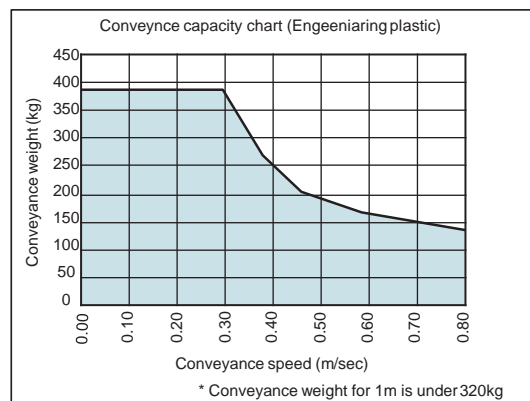

Dimension

Reduction ratio 1/30 to 1/60
(note 3)

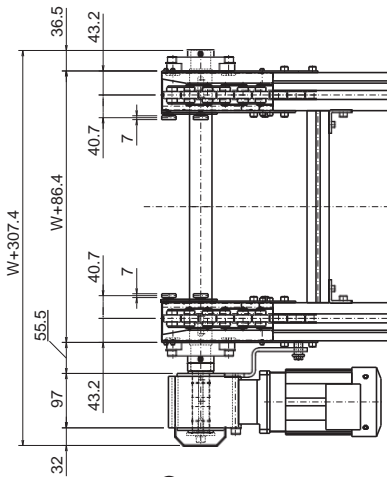

Reduction ratio 1/80 to 1/200
(note 3)

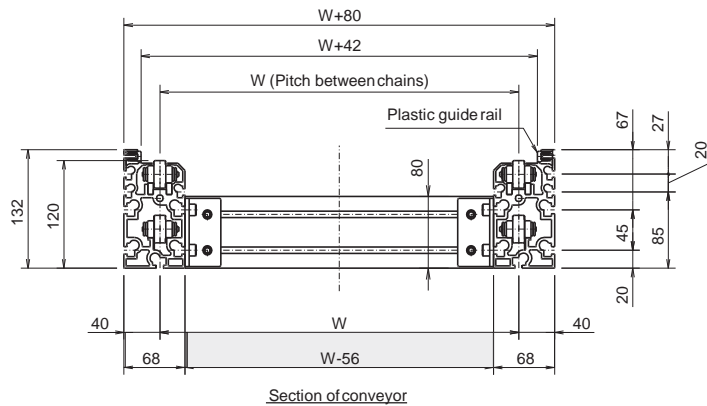
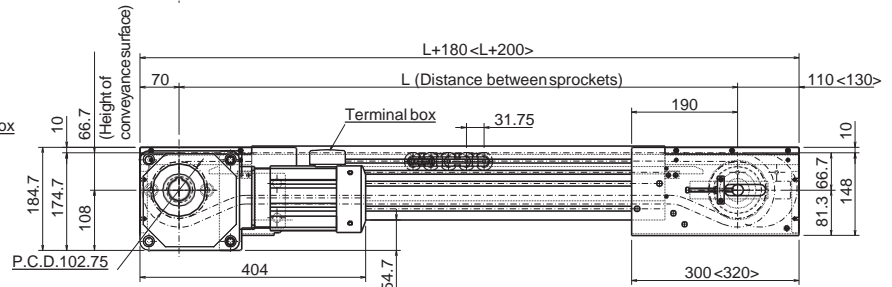
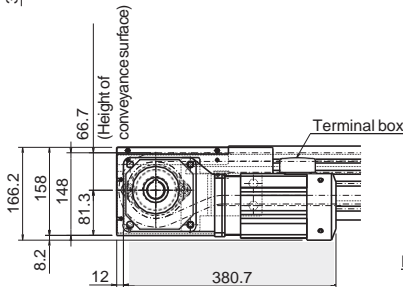
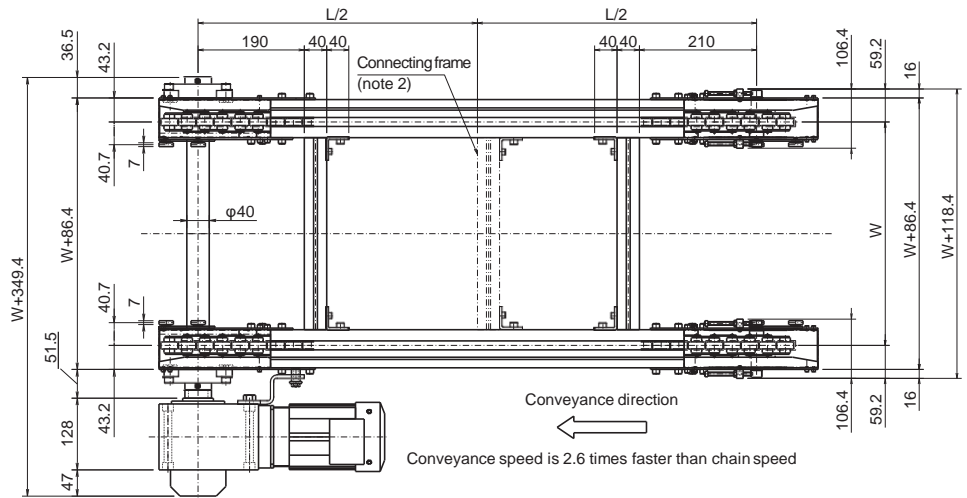

(Note1) The number of <> is size for Distance between sprockets over 3001mm
(Note2) When Distance between sprockets is over 2501mm, connecting frame is used in this position
(Note3) The motor size is different between Reduction ratio 1/30 to 1/60 and Reduction ratio 1/80 to 1/200



Safety precautions

- Read the instructions before using this product
- Please use within the specification designated by the catalog and instructions

NKE Corporation

◆ Head office Works

366-1, Hishikawa-cho, Hazukashi, Fushimi-ku, Kyoto, Japan

◆ E-mail

promotion@nke.co.jp

◆ HP

<https://www.nke.co.jp/>

●Please kindly understanding for changing the contents of this leaflet without your approval.

©2021 NKE Corporation

P-CS211102AE